

ICE DOUBLE HORIZONTAL ELEC

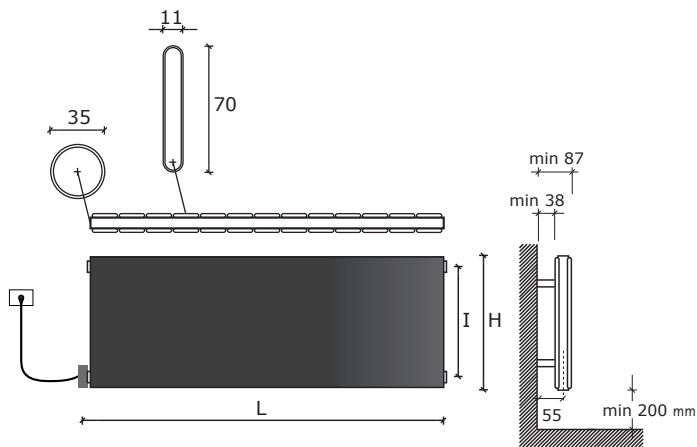

Interasse dal centro foro al muro 55 mm.
Distance between hole center and wall 55 mm.
Distance du centre du trou au mur 55 mm.
Abstand zwischen Lochmitte und Wand 55 mm.
Distancia entre el centro del agujero y el muro 55 mm.
Расстояние между центром отверстия и стеной – 55 мм.



Resistenza solo a sinistra e inserita orizzontalmente nel collettore.
Electric element only on the left side and inserted horizontally into the manifold.

Resistance électrique seulement à gauche et insérée horizontalement dans le collecteur.

Heizpatrone nur links und im Kollektor horizontal eingesetzt.

Resistencia sólo a la izquierda y insertada horizontalmente en el colector.

Электротен только справа и расположен вертикально в коллекторе.



H1 / H2

NEWS

Resistenza elettrica con costo aggiuntivo del 3%
potenza elettrica resistenza **MAX 1000watt**

Electric resistance with additional cost 3%
output for electrical version **MAX 1000watt**

Resistance électrique avec coût supplémentaire 3%
puissance en version électrique **MAX 1000watt**

Heizstab mit Mehrpreis 3%
Leistung der elektrischen Ausführung **MAX 1000watt**

Resistencia eléctrica con costo adicional 3%
output version eléctrica **MAX 1000watt**

Электрическое сопротивление за дополнительную плату 3%
мощность электрического варианта **MAX 1000watt**

ICE DOUBLE HORIZONTAL ELEC



codice code Artikel Nr. código код	altezza height hauteur Höhe altura высота	larghezza* width* largeur* breite* ancho* ширина*	interasse distance between bars entraxe Achsabstand distancia entre centros межцентровое расстояние	peso radiatore + glicole weight of radiator + glycole pois du radiateur + glycol Gewicht inkl. Glykol peso radiador + glycole вес радиатор + гликоль	output versione idraulica output water heating puissance en version eau chaude Leistung der Wasser- ausführung output version agua calda мощность гидравлического варианта	potenza elettrica resistenza output for electrical version puissance en version électrique Leistung der elektrischen Ausführung output version eléctrica мощность электрического варианта
	H mm	L mm	I mm	Kg	Δt50 watt*	watt*
FICE12520...	520	1315	460	48	966	1000
FICE12620...	620	1315	560	58	1221	1400

- * I watt hanno valori provvisori in attesa di certificazione Δt50.
- * The watt values are not definitive awaiting for Δt50 certification.
- * Le nombre de Watts est une valeur indiquée à titre provisoire dans l'attente de la certification Δt50.
- * Die Wattwerte sind noch provisorisch in Erwartung von Δt50 Zertifizierung.
- * Los Vativos tienen valores provisionales en espera de la certificación Δt50.
- * До получения сертификата Δt50 приводится предварительное значение мощности в ваттах.

<ul style="list-style-type: none"> * Incluso il termostato analogico di 110 mm * Included 110 mm high analogic room control * Inklus boitier de régulation analogique de 110 mm * Inkl. Raumthermostat (110 mm) * Includido termostato por ambiente analogico de 110 mm * Включающая аналоговый термостат 110 мм 	<p>Scatola termostato bianca di serie per radiatori bianchi. Scatola termostato cromata di serie per radiatori colorati e finiture inox. Standard white thermostat box for white radiators. Standard chromed thermostat box for coloured and stainless steel finishings radiators. Boîtier thermostat blanc de série pour radiateurs blancs. Boîtier thermostat chromée de série pour radiateurs colorés et finitions inox. Serienmäßig weißes Thermostatgehäuse für weiße Heizkörper. Serienmäßig verchromte Thermostatgehäuse für bunte Heizkörper und Edelstahlfinish. Caja de termostato blanca de serie para radiadores blancos. Caja de termostato cromado de serie para radiadores coloreados y acabados inox. Корпус термостата белый стандартный для белых радиаторов. Стандартный хромированный термостат для цветных радиаторов и радиаторов в отделке нержавеющей стали.</p>
--	--

<p>I radiatori sono completi di kit di fissaggio a parete e valvola di sfogo. La versione cromata NON è disponibile. Pressione di collaudo: 5,2 bar Pressione di esercizio: 4 bar Materiale: Acciaio al carbonio</p>	<p>The radiators are equipped with a kit for fixing them to the wall and with an exhaust valve. Chromed radiators NOT available. Testing pressure: 5,2 bar Working pressure: 4 bar Material: carbon-steel</p>	<p>Les radiateurs sont munis d'un kit de fixation murale et d'une soupape de décompression. La version chromée N'EST PAS disponible. Pression d'essai: 5,2 bars Pression d'exercice: 4 bars Matière: Acier au charbon</p>	<p>Die Heizkörper sind mit Wandbefestigungsset und Luftventil ausgerüstet. Die verchromte Version ist NICHT verfügbar. Prüfungsdruck: 5,2 bar Betriebsdruck: 4 bar Stoff: Kohlenstoffstahl</p>	<p>Los radiadores están provistos de kit de fijación a la pared y de válvula de desahogo. La versión cromada NO está disponible. Presión de ensayo: 5,2 bar Presión de trabajo: 4 bar Material: Acero de carbono</p>	<p>Радиаторы укомплектованы набором крепежных деталей для закрепления на стене и выпускным клапаном. Хромированная версия в продаже ОТСУТСТВУЕТ. Давление при испытании – 5,2 бар Рабочее давление – 4 бар Материал – углеродистая сталь</p>
---	--	--	---	---	---

B

50 mm destro.
50 mm right.
50 mm droite.
50 mm rechts.
50 mm derecha.
50 мм вправо

Interasse Destro 50 mm **a richiesta.**
Right distance between centers 50 mm **on request.**
Entraxe Droite 50 mm **sur demande.**
Rechtsanschluss 50 mm **Auf Anfrage.**
Distancia entre Derecha de 50 mm, **bajo pedido.**
По запросу радиатор может выполняться с право межосевым расстоянием, равным 50 мм.